

CENTER MOUNTED RESERVOIR

E1 = ELECTRICAL DL = DRAIN

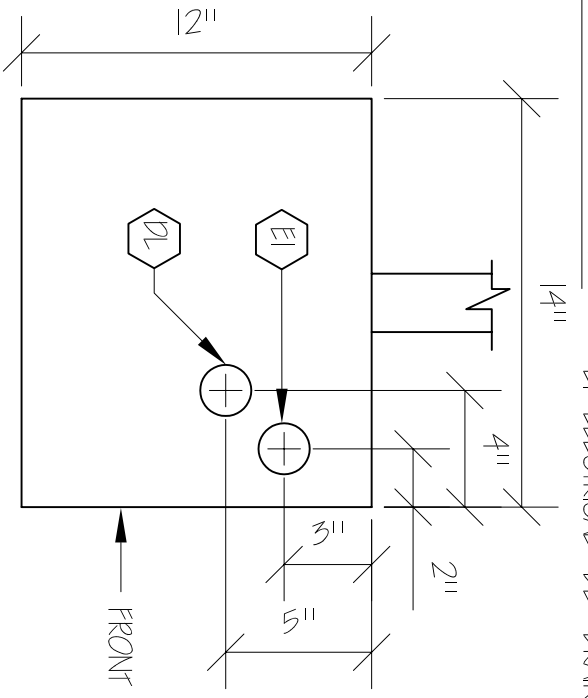

1 LEFT SIDE
1.00 OPTION #1

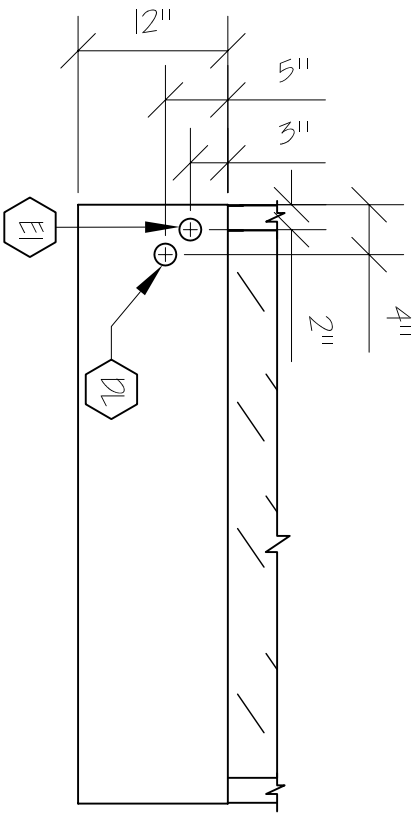

3 BACK RIGHT
1.00 OPTION #3

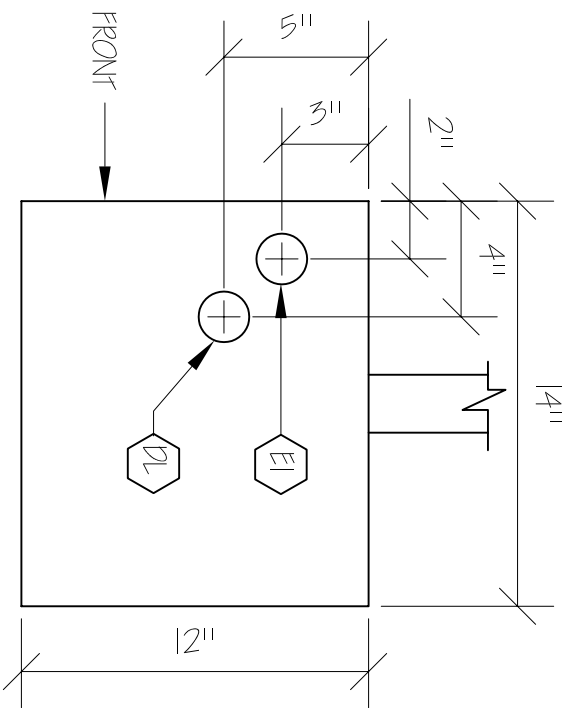

2 RIGHT SIDE
1.00 OPTION #2

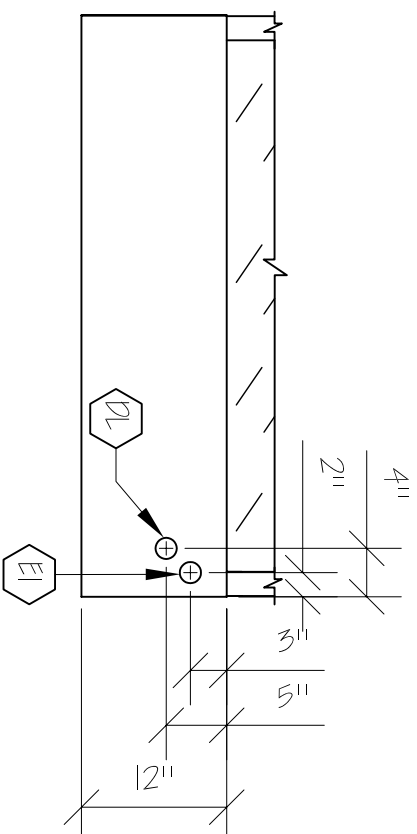

4 BACK LEFT
1.00 OPTION #4

MATERIAL SPECIFICATION

QTY.	ITEM	MATERIAL
1		

BLU WORLD
635 W Michigan St
Orlando, FL 32805
407.426.7674
#407.426.7721
www.blumorldusa.com

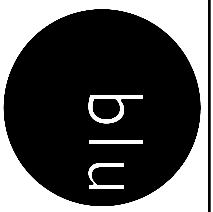

CLIENT: _____
INVOICE #: _____
DATE: 3/2/09
DRAWN BY: _____
APPROVED BY: _____
SHEET TITLE:
Water Feature Specifications
CENTER MOUNTED
RESERVOIR

100
SHEET NUMBER